

LIFT TABLE SPECIFICATIONS

ROCKY MOUNTAIN
DESK ★ CO

COLOUR: Colour Code:	 White BL	 Grey GA	 Black NR
	FINISH: Glossy 		

Name: V-Flex II - 2
 Model #: SHLTM-3LADJ23.5-*/3M-2

ACTIVATION

ELECTRICAL

3-motor

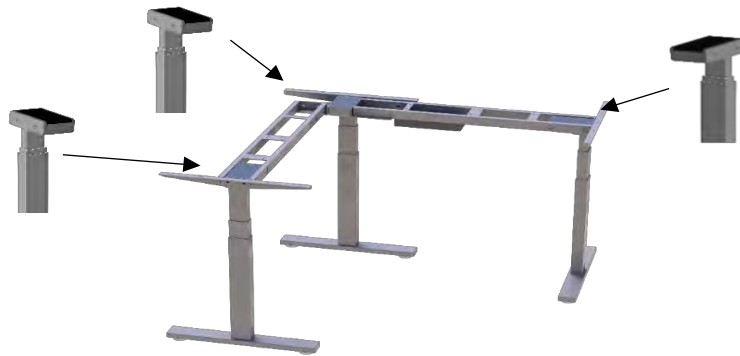

SENSOR PRESSURE



TYPE OF REMOTE



Touch Remote

NUMBER ON THE DISPLAY AT THE
 LOWEST AND HIGHEST SETTINGS (INCHES)

H: 44.6

L: 24

TELESCOPIC LEG

Narrows at Top

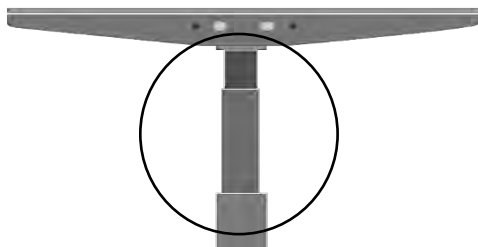

NUMBER OF LEG SECTIONS

3 Sections

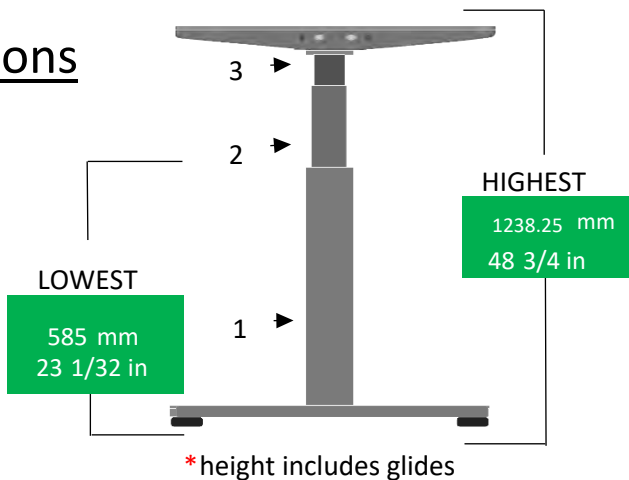

GLIDES

Threading:

M6

3/4in

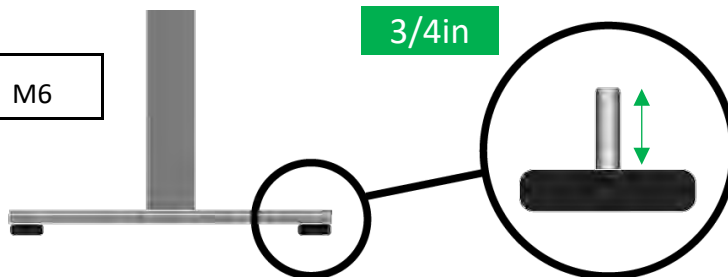

BODY

TABLE SUPPORT DETAILS

2 Legs

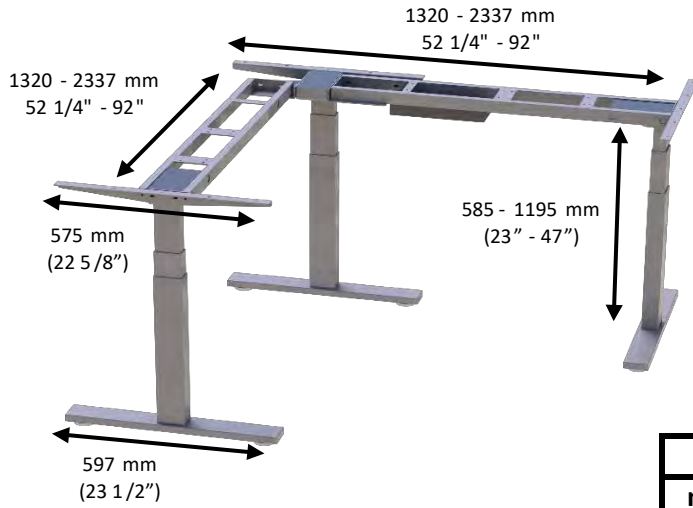

WIDTH RANGE

	Smallest	Biggest
in	52 1/4	92
mm	1320	2337

END SUPPORT AND FEET

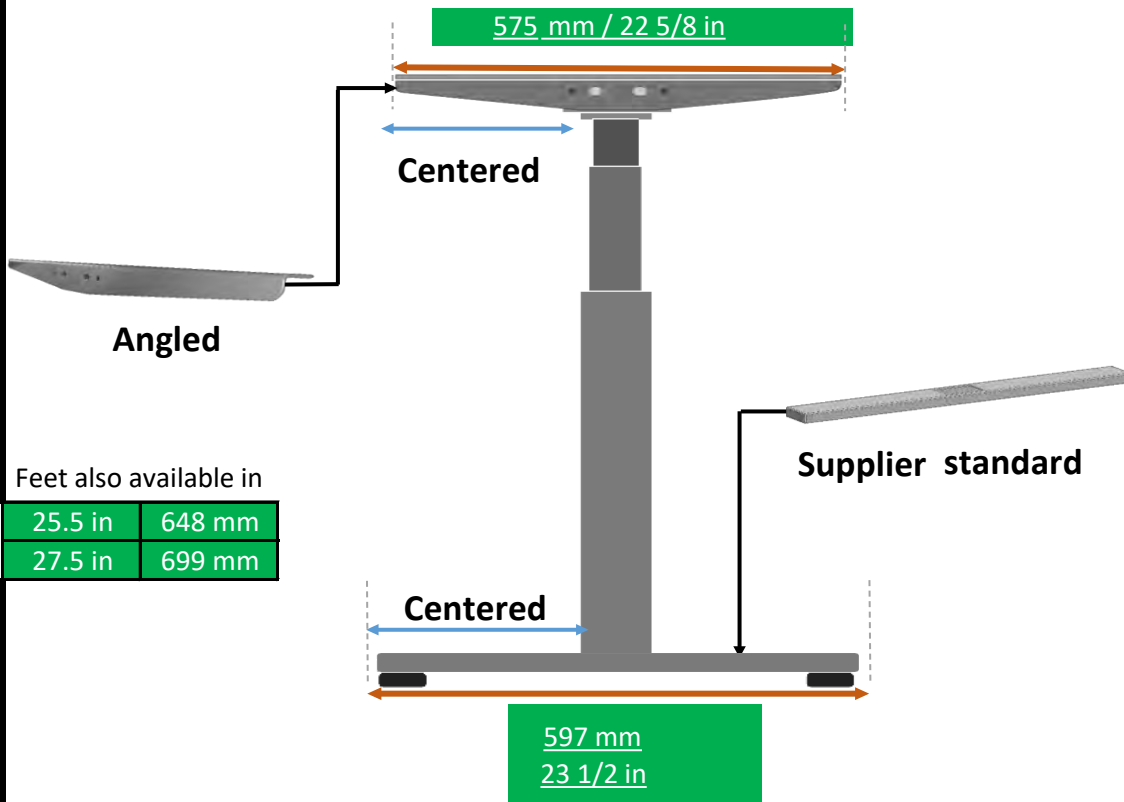

PACKAGING

Amount of boxes

2 boxes

Protection requirements

Foam

TECHNICAL SPECIFICATIONS

Operation Speed:

in/seconds

1 1/4

Sound Level:

< 50 db

Weight Capacity:

Kgs

122.5

Lbs

270

Duty Cycle:

Max .10% or 2 min.on and 18

Certifications:



Power (A/V, Hz):

110V-50/60HZ

Idle Consumption

< 0.5 W

